

CATHEDRAL BRONZE SILVERED

PRODUCT INFORMATION

Cathedral Bronze Silvered Glass, part of Nathan Allan's exclusive Freeform Series, is exciting, new, and the first "texture less" kiln formed glass in our industry. Designed for architects and interior designers who prefer a structured linear glass pattern for their projects. Our Cathedral Bronze Silvered texture has tight, 1.5" (38mm) wide, protruding Convex shaped flutes. The protruding pattern creates a 3D surface effect. Illuminating this 3D effect is the Silvered (Mirror) finish applied to the back surface. The Silvered finish reflects light and highlights the Cathedral Bronze Silvered texture to another level. Ideal for all cladding applications where the glass can be pressed against another wall surface, to hide or block the surface. A perfect application for our Cathedral Bronze Silvered Glass is the back wall of any hotel registration area or entrance lobby. Also, apply our Silvered glass options to make a simple column become bold and vibrant.



STANDARD MAXIMUM PANEL SIZE
 - Single layers of tempered glass

1/4" Glass - 4'0 x 9'0 (6mm glass - 1219mm x 2743mm)
 3/8" Glass - 3'0 x 8'0 (10mm - 914mm x 2438mm) - Custom sizes available up to 5'0 x 10'0 (1500mm x 3000mm) - Extra Charges Apply
 1/2" Glass - 2'6 x 8'0 (12mm - 762mm x 2438mm) - Custom sizes available up to 5'0 x 10'0 (1500mm x 3000mm) - Extra Charges Apply

STANDARD MAXIMUM PANEL SIZE
 - Double layers of laminated glass

1/2" Glass - 4'0 x 9'0 (12mm glass - 1219mm x 2743mm)
 5/8" Glass - 5'0 x 10'0 (15mm glass - 1524mm x 3048mm)

PANEL THICKNESS	3/8"	1/2"
	10 MM	12 MM
Clear	.	.
Low Iron	.	.
Black	.	.
Bronze	.	.

Edgework Machine flat polished

Safety Tempered, Laminated

Cleaning Our glass products can be cleaned with liquid cleaners and paper towels, or soft clothes. Liquid cleaners with out ammonia will help reduce streaks on the glass. Avoid all abrasive cleaning materials.

Flat Margins Outside Vertical Edges - from 1/4" to 3/4" (6mm to 19mm).
 Interior Vertical Edges - 1/8" to 1/4" (4mm to 6mm)

Pattern Details If using 3/8" (10mm) thick flat glass, after pattern is formed, overall pattern thickness increases to 5/8"(15mm). Pattern thickness may vary , so allow 1/16" (2mm) variance. Front surface has a Convex shape, while back surface has a Concave shape. Individual flutes are 1.5" (38mm) wide.

CATHEDRAL GLASS PROFILE, SECTION VIEW

CATHEDRAL GLASS TOP | BOTTOM SECTION VIEW

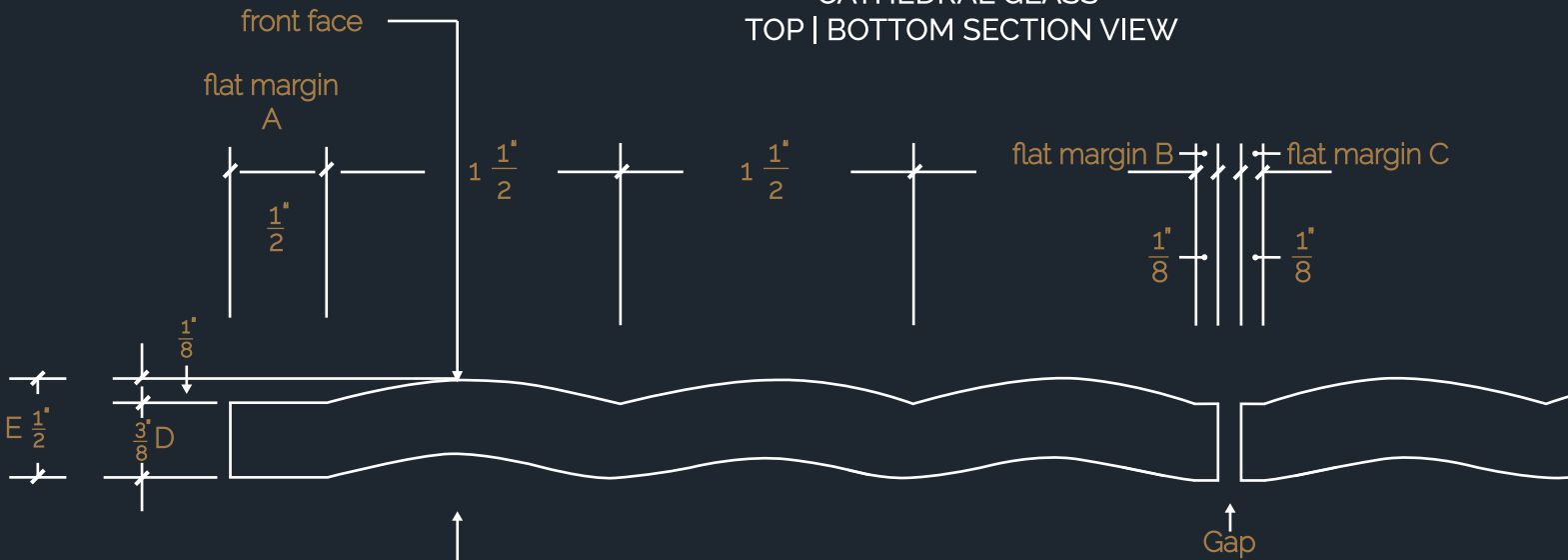

flat margin A – produced on the outside Vertical edge of panel, where glass is inserted into channel or molding. Outside flat margins will typically range from 1/4" to 3/4" wide

flat margins B + C – produced on the inside Vertical edges of panels, where panels are installed side x side. Inside flat margins will typically be 1/8" wide or less

D – indicates thickness of flat section of glass

E – indicates overall pattern thickness of glass

(Please note that the pattern thickness depth can vary slightly, from 1/16" to 1/8", on some panels)

CATHEDRAL GLASS TOP | BOTTOM SECTION VIEW

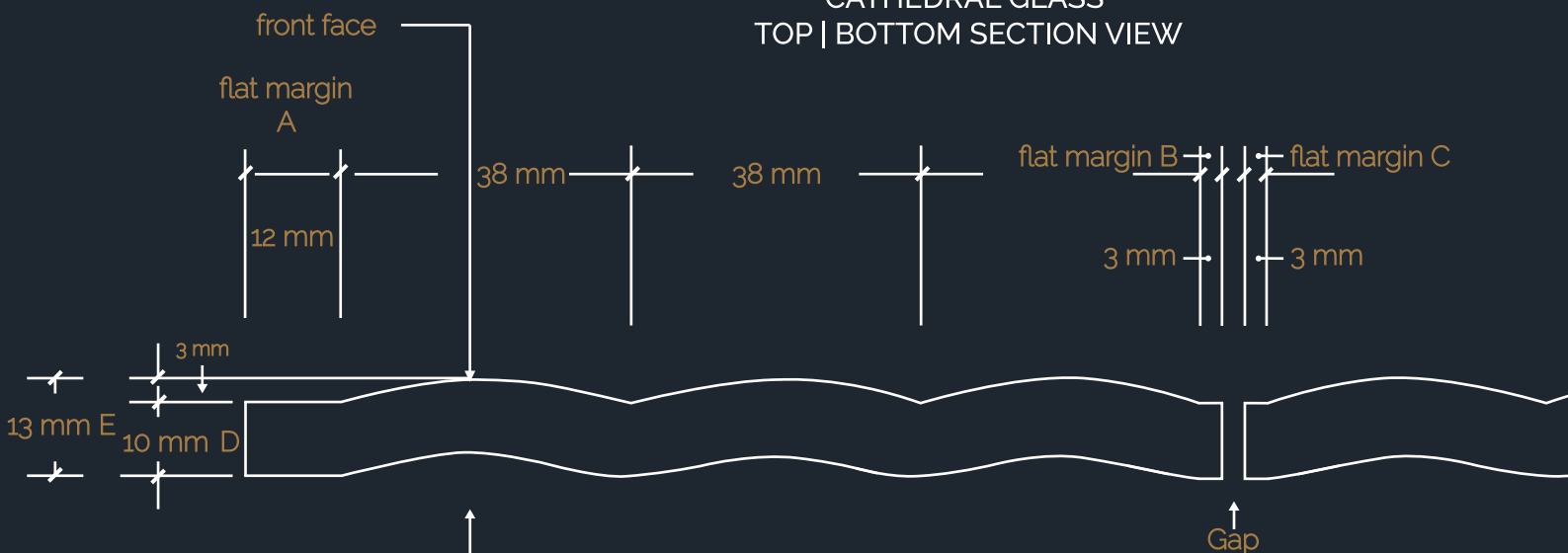

flat margin A – produced on the outside Vertical edge of panel, where glass is inserted into channel or molding. Outside flat margins will typically range from 6 mm to 19 mm wide

flat margins B + C – produced on the inside Vertical edges of panels, where panels are installed side x side. Inside flat margins will typically be 3 mm wide or less

D – indicates thickness of flat section of glass

E – indicates overall pattern thickness of glass

(Please note that the pattern thickness depth can vary slightly, from 2mm to 4mm, on some panels)